



# TD-9R

CRAWLER DOZER  
STD & LGP

■ **Net Horsepower**  
93 hp (69 kW)

■ **Blade Capacity**  
2.45 yd<sup>3</sup> (1.87 m<sup>3</sup>)  
2.30 yd<sup>3</sup> (1.76 m<sup>3</sup>)

■ **Operating Weight**  
20,095 lb (9115 kg) STD  
20,483 lb (9291 kg) LGP



# TD-9R

## CRAWLER DOZER

### STD & LGP

- Full power shift transmission
- Highly efficient torque converter
- Wet-type steering clutches and brakes
- Hydraulic lift, tilt & angle blade
- Left joystick for transmission and steering control



## ENGINE

* Make and Model .....	CUMMINS QSB3.3
Type .....	In-line, 4-cylinder
Aspiration .....	Turbocharged and CAC
Fuel system .....	Electronic
Gross Horsepower, SAE J 1995 .....	99 hp (74 kW)
Net Horsepower, SAE J 1349/ISO 9249 .....	93 hp (69 kW)
Rated rpm .....	2200 rpm
Max. torque @1600 rpm .....	306 ft-lb (414 Nm)
Displacement .....	199 in <sup>3</sup> (3.3 l)
Bore and Stroke .....	3.74" x 4.53" (95 x 115 mm)
Air cleaner .....	two stage, dry type with service indicator

\*Meets EU Stage IIIA and EPA Tier 3 emission regulations

## TRANSMISSION & TORQUE CONVERTER

Modular countershaft type full power shift, electro-hydraulically actuated with 3 speeds forward, 3 reverse. Joystick control valve has electric transmission range shift control for up and down shifting. Single stage 11" (280 mm) torque converter with 1.986:1 stall ratio drives to transmission through a permanently lubricated double universal joint.

## TRAVEL SPEEDS

Gear	Forward		Reverse	
	mph	(km/h)	mph	(km/h)
1 st	2.0	(3.3)	2.3	(3.8)
2 nd	3.3	(5.3)	3.9	(6.3)
3 rd	5.5	(8.9)	6.5	(10.4)

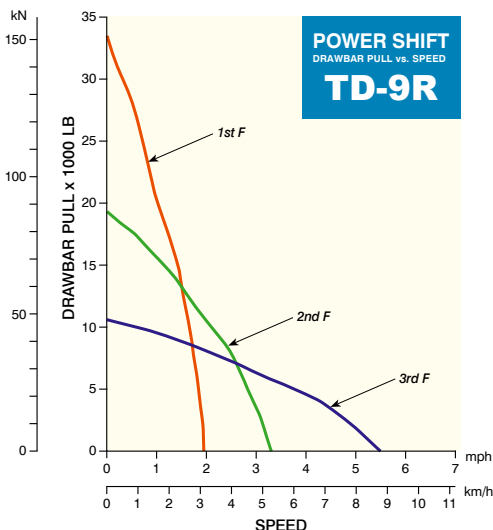

## STEERING & BRAKING

Single stage planetary type, wet single disc steering clutches. Single disc, wet-type steering brakes. Steering clutches and brakes run in oil and are hydraulically actuated. The left hand joystick controls transmission and steering drive. Right foot pedal applies decelerator and brake for parking. Left pedal applies disc brakes for downhill speed control. Brakes are spring applied and hydraulically released.

## FINAL DRIVES

Single stage spur-gear drive to sprockets 8.1:1 reduction ratio. Final drive has metal face seals. Operates in oil for long life. Sprockets are replaceable without removing track frames.

## TRACK FRAME

Heavy steel box section, rigid mount.  
 Track rollers each side ..... 6  
 Top idlers each side ..... 1  
 Front idlers (disc type) ..... casting  
 All rollers and idlers ..... lifespan lubricated

## TRACKS

Lubricated Track System virtually eliminates internal pin and bushing wear.

	STD	LGP
Track shoe width	18" (457 mm)	24" (610 mm)
Track shoes, each side	39	39
Ground contact area	3,096 in <sup>2</sup> (1.99 m <sup>2</sup> )	4,128 in <sup>2</sup> (2.67 m <sup>2</sup> )
Ground pressure	6.49 psi (44.75 kPa)	4.96 psi (34.2 kPa)
Strutted track link pitch	6.5" (165 mm)	
Height of grouser	2.11" (53.6 mm)	
Track adjustment	full hydraulic	
Minimum ground clearance		
from bottom face of shoe	15" (381 mm)	
Recovery hitch-height		
from ground to centerline of clevis	21.1" (536 mm)	

## REFILL CAPACITIES

	US gal	(Liter)
Fuel tank	45.0	(170.0)
Cooling system	4.0	(15.2)
Crankcase	1.8	(7.0)
Transmission & steering drive	17.2	(65.0)
Final drive, each side	4.0	(15.1)

## OPERATING WEIGHT

Includes hydraulic angle blade, standard equipment and full fuel.

	STD	LGP
Canopy ROPS/FOPS	20,095 lb (9115 kg)	20,483 lb (9291 kg)
Cab ROPS/FOPS	20,745 lb (9410 kg)	21,133 lb (9586 kg)

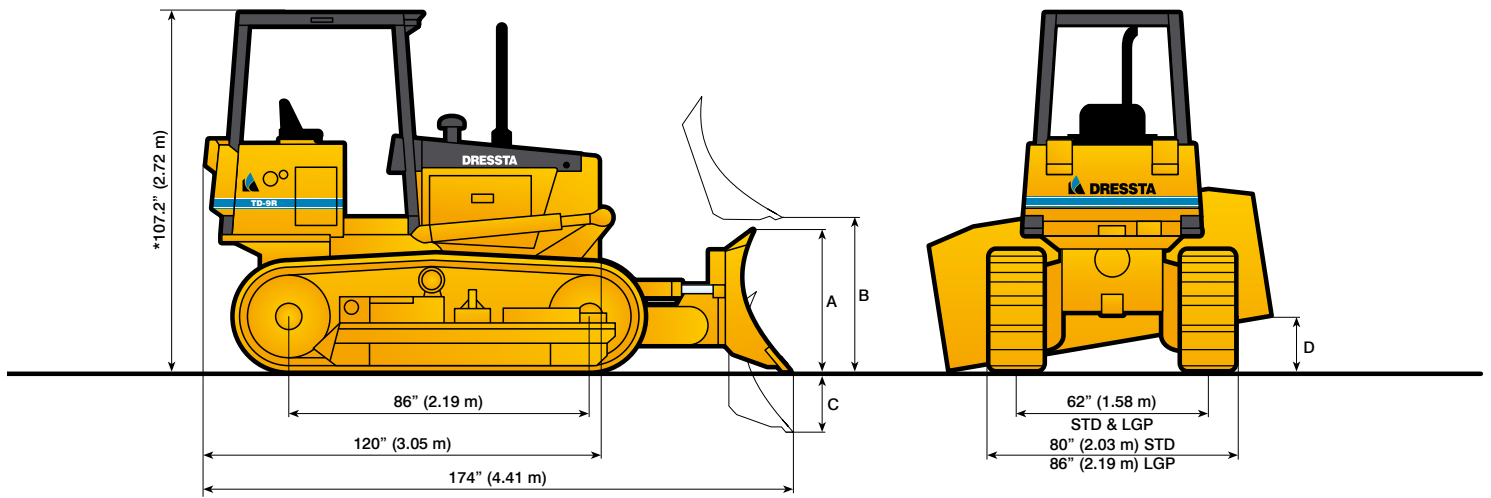

\* Dimension includes 2.11" (53.6 mm) grouser height  
 Overall height with Cab ROPS – 108.5" (2.76 m)

## OVERALL DIMENSIONS WITH EQUIPMENT

Type of Track Frame	STD	LGP
Length, with blade and ripper	16'1" (4.90 m)	16'1" (4.90 m)
Width, blade angled	8'0" (2.44 m)	8'5" (2.57 m)
Width, blade straight	8'10" (2.69 m)	9'3" (2.82 m)

## BLADE SPECIFICATIONS

Type of Track Frame		STD	LGP
Blade capacity, SAE J1265		2.45 yd <sup>3</sup> (1.87 m <sup>3</sup> )	2.30 yd <sup>3</sup> (1.76 m <sup>3</sup> )
Max. usable track shoe width		20" (508 mm)	24" (610 mm)
Blade dimensions:	– width over end bits	8'10" (2.69 m)	9'3" (2.82 m)
	– height, struts centered	A	3'1" (0.95 m)
Max. lift, straight	B	34.3" (0.87 m)	34.3" (0.87 m)
Max. drop below ground level	C	16.5" (0.42 m)	16.5" (0.42 m)
Max. tilt adjustment	D	15.7" (0.40 m)	16.4" (0.42 m)
Blade angle, either side		25°	25°

## RIPPER SPECIFICATION

Type .....	Multi-Shank		
Tool Beam		Shanks	
Overall width .....	4'9" (1.44 m)	Number of shanks per ripper, max. ....	5
Cross section, height x width.....	6.5" x 6.5" (165 x 165 mm)	Spacing center to center .....	13.5" (343 mm)
Ground clearance under tool beam .....	28.2" (716 mm)	Penetration, max. ....	12.0" (305 mm)
Weight		Ground clearance, max. raised .....	16.6" (422 mm)
Complete, including three shanks .....	1,120 lb (510 kg)	Shank positions (vertical).....	2
Each additional shank .....	20 lb (9 kg)		

## HYDRAULIC CONTROL SYSTEM

Pump, tandem gear.		Cylinders, bore and stroke	
Output @ 500 psi (3.45 MPa)		Lift (2) .....	3.5" x 17.7" (89 x 449 mm)
& rated engine rpm .....	18.4 gpm (69.6 l/min)	Angle (2).....	3.5" x 13.9" (89 x 352 mm)
Relief valve setting		Tilt (1) .....	3.5" x 5.7" (89 x 144 mm)
Blade lift & ripper .....	2,250 psi (15 512 kPa)	Reservoir with sight gauge, system capacity, right fender mounted,	
Tilt.....	2,250 psi (15 512 kPa)	includes cylinders & lines .....	13.5 gal (51 l)



# TD-9R

## CRAWLER DOZER

### STD & LGP



## STANDARD EQUIPMENT

- Air cleaner, dry type, with primary and safety elements and service indicator
- Alarm, back-up, 2 level sound
- Alternator, 120 A
- Antifreeze, -34°F (-37°C)
- Battery, (1) 12 V, 815 CCA, maintenance free
- Canopy ROPS/FOPS (SAE J1040, J231) with roof extension, roof headliner, mirror
- Cooling module; includes radiator, transmission oil cooler and charge air cooler; isolation mounted
- Counterweights, front idler
- Cup holder
- Decelerator/brake – right pedal and brake – left pedal, brake pedal lock button, foot operated
- Engine hood, solid
- Engine side doors, perforated
- Engine speed control knob, L.H. location
- Fan, blower
- Filters, with “spin-on” elements: engine oil, fuel, power train, equip. hyd.
- Guards: crankcase with pull hook, lights, radiator, transmission, rock deflector, fan, fuel tank bottom and back-up alarm
- Hitch, retrieval
- Horn
- Hydraulics, 3-spool valve, “T” control
- Instruments:
  - Gauges: fuel level, coolant temperature, engine oil pressure, power train oil temperature, voltmeter, hourmeter
  - Warning lights: transmission filter service indicator, air filter and hydraulic filter service indicator
- Lights, 2 front, 1 rear, halogen type
- Muffler, underhood with exhaust pipe and elbow
- Power train diagnostic check panel w/brake release port
- Protection guard for fuel tank and filler
- Radiator guard door, louvered
- Seat belt (SAE J386) – 3” wide, retractable
- Seat, suspension type with adjustable arm rests
- Starting aid – air grid heater
- Starting, 12 V
- Steering & transmission, left hand single lever control, joystick w/safety lever
- Strainer, fuel
- Tools compartment
- Torque converter, single stage
- Track adjusters, hydraulic
- Track chains, sealed & lubricated (LTS) with split master links, 39 links
- Track frame, 6 rollers, 62” (1.58 m) gauge, rigid type, lifespan lubricated rollers and idlers, front and rear chain guides
- Track frame covers
- Track shoes, 18” (457 mm), set of 78
- Transmission, full power shift, 3 speeds forward, 3 reverse
- Water separator, fuel system

## OPTIONAL ATTACHMENTS

- Air conditioner/heater/pressurizer/defroster
- Angle dozer 2.45 cu.yd (1.87 cu.m), standard width, inside arm w/hyd. tilt & angle, for STD
- Angle dozer 2.30 cu.yd (1.76 cu.m) wide, inside arm w/hyd. tilt & angle for LGP
- Battery, cold start, 12 V, 960 CCA
- Cab, ROPS/FOPS with sound suppression, wipers (4) and washers, mirror, dome light & tinted safety glass
- Defroster fan (for use w/cab)
- Forestry front sweeps w/exhaust pipe (for use w/cab or canopy ROPS/FOPS)
- Guards:
  - track roller, std. strength
  - track roller, full length, heavy duty type
- Heater/pressurizer/defroster
- Hood, perforated (blower fan recommended)
- Hydraulics, 4-spool valve, 2 levers (“T”+ single), for use w/ripper or auxiliary attachments
- Mirrors, 2 pcs (for use w/cab)
- Resonator, exhaust
- Ripper, multi-shank w/3 teeth (provision for 5 teeth)
- Screening package, black painted (Canopy ROPS for screens installation must be ordered)
  - screens, front
  - screen, rear
  - doors and side screens w/third post
  - screen, overhead, for upper front lights protection (for use w/sweeps)
- Seat, suspension type with adjustable arm rests (for use with cab)
- Track shoes:
  - 18” (457 mm) w/mud relief, 20” (508 mm), set of 78, for STD
  - 24” (610 mm), set of 78, for LGP
- Vandalism protection

Specifications subject to change without notice. Illustrations may include optional attachments and accessories and may not include all standard equipment.

NOTE: Low Ground Pressure (LGP) tractors are designed for use in mud, snow and other soft ground applications.

Use in hard or rocky conditions will reduce undercarriage life and can cause damage to components.

## DRESSTA NORTH AMERICA, LTD.

3 TIMBER COURT  
 BOLINGBROOK, IL 60440  
 phone (630) 759 9530 fax (630) 759 9534  
 Toll free (877) DNA 2001  
 www.dresstanorthamerica.com