



TD-8R

CRAWLER DOZER
STD & LGP

■ **Net Horsepower**
78 hp (58 kW)

■ **Blade Capacity**
2.20 yd³ (1.68 m³)
1.90 yd³ (1.45 m³)

■ **Operating Weight**
18,034 lb (8180 kg) STD
18,774 lb (8516 kg) LGP



TD-8R

CRAWLER DOZER

STD & LGP

- Full power shift transmission
- Highly efficient torque converter
- Wet-type steering clutches and brakes
- Hydraulic lift, tilt & angle blade
- Left joystick for transmission and steering control



ENGINE

* Make and model	CUMMINS QSB3.3
Type	In-line, 4-cylinder
Aspiration	Turbocharged and CAC
Fuel system	Electronic
Gross Horsepower, SAE J 1995	85 hp (63 kW)
Net Horsepower, SAE J 1349/ISO 9249	78 hp (58 kW)
Rated rpm	2600 rpm
Max. torque @1400 rpm	274 ft-lb (371 Nm)
Displacement	199 in ³ (3.3 l)
Bore and Stroke	3.74" x 4.53" (95 x 115 mm)
Air cleaner	two stage, dry type with service indicator

*Meets EU Stage IIIA and EPA Tier 3 emission regulations

TRANSMISSION & TORQUE CONVERTER

Modular countershaft type full power shift, electro-hydraulically actuated with 3 speeds forward, 3 reverse. Joystick control valve has electric transmission range shift control for up and down shifting. Single stage 11" (280 mm) torque converter with 2.079:1 stall ratio drives to transmission through a permanently lubricated double universal joint.

TRAVEL SPEEDS

Gear	Forward		Reverse	
	mph	(km/h)	mph	(km/h)
1 st	2.1	(3.4)	2.5	(4.0)
2 nd	3.5	(5.6)	4.1	(6.6)
3 rd	5.8	(9.3)	6.7	(10.7)

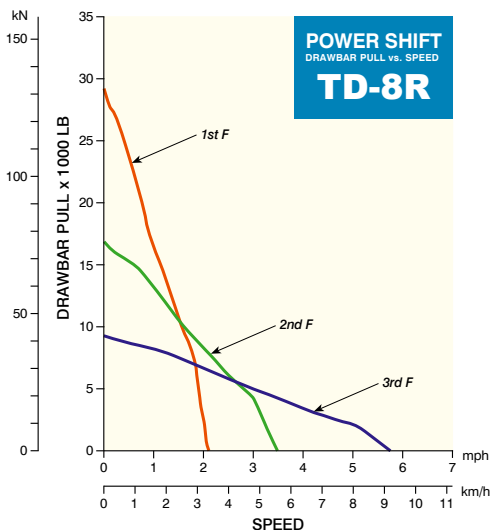

STEERING & BRAKING

Single stage planetary type, wet single disc steering clutches. Single disc, wet-type steering brakes. Steering clutches and brakes run in oil and are hydraulically actuated. The left hand joystick controls transmission and steering drive. Right foot pedal applies decelerator and brake for parking. Left pedal applies disc brakes for downhill speed control. Brakes are spring applied and hydraulically released.

FINAL DRIVES

Single stage spur-gear drive to sprockets 5.66:1 reduction ratio. Final drive has metal face seals. Operates in oil for long life. Sprockets are replaceable without removing track frames.

TRACK FRAME

Heavy steel box section, rigid mount.

Track rollers each side	6
Top idlers each side	1
Front idlers (disc type)	casting
All rollers and idlers	lifespan lubricated

TRACKS

Lubricated Track System virtually eliminates internal pin and bushing wear.

	STD	LGP
Track shoe width	15" (381 mm)	24" (610 mm)
Track shoes, each side	37	37
Ground contact area	2,460 in ² (1.59 m ²)	3,936 in ² (2.54 m ²)
Ground pressure	7.33 psi (50.5 kPa)	4.77 psi (32.9 kPa)
Strutted track link pitch	6.5" (165 mm)	
Height of grouser	2.11" (53.6 mm)	
Track adjustment	full hydraulic	
Minimum ground clearance		
from bottom face of shoe	12.7" (323 mm)	
Recovery hitch-height		
from ground to centerline of clevis	18.8" (477 mm)	

REFILL CAPACITIES

	US gal	(Liter)
Fuel tank	45.0	(170.0)
Cooling system	4.0	(15.2)
Crankcase	1.8	(7.0)
Transmission & steering drive	17.2	(65.0)
Final drive, each side	2.5	(9.5)

OPERATING WEIGHT

Includes hydraulic angle blade, standard equipment and full fuel.

	STD	LGP
Canopy ROPS/FOPS	18,034 lb (8180 kg)	18,774 lb (8516 kg)
Cab ROPS/FOPS	18,684 lb (8475 kg)	19,425 lb (8811 kg)

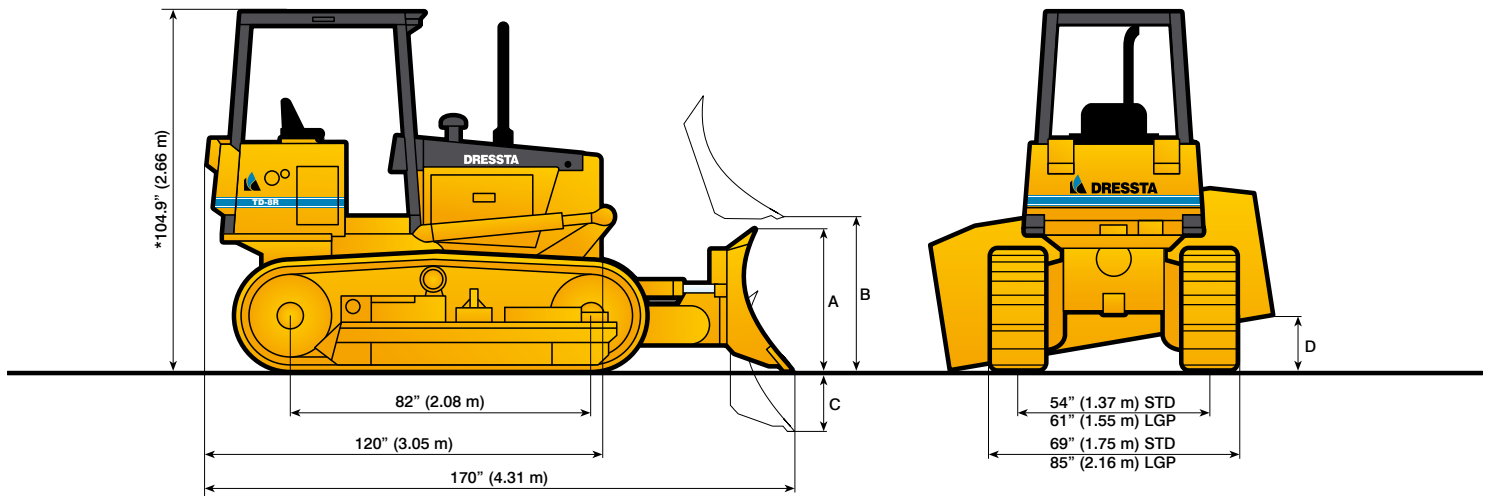

* Dimension includes 2.11" (53.6 mm) grouser height
 Overall height with Cab ROPS – 106.2" (2.70 m)

OVERALL DIMENSIONS WITH EQUIPMENT

Type of Track Frame	STD	LGP
Length, with blade and ripper	15'9" (4.80 m)	15'9" (4.80 m)
Width, blade angled	7'10" (2.39 m)	8'5" (2.57 m)
Width, blade straight	8'7" (2.62 m)	9'3" (2.82 m)

BLADE SPECIFICATIONS

Type of Track Frame	STD	LGP
Blade capacity, SAE J1265	2.20 yd ³ (1.68 m ³)	1.90 yd ³ (1.45 m ³)
Max. usable track shoe width	17" (432 mm)	24" (610 mm)
Blade dimensions:		
– width over end bits	8'7" (2.62 m)	9'3" (2.82 m)
– height, struts centered	A	
Max. lift, straight	B	
Max. drop below ground level	C	
Max. tilt adjustment	D	
Blade angle, either side	25°	25°

RIPPER SPECIFICATION

Type	Multi-Shank
Tool Beam	Shanks
Overall width	4'9" (1.44 m)
Cross section, height x width	6.5" x 6.5" (165 x 165 mm)
Ground clearance under tool beam	25.9" (658 mm)
Weight	
Complete, including three shanks	1,120 lb (510 kg)
Each additional shank	20 lb (9 kg)
	Number of shanks per ripper, max.
	5
	Spacing center to center
	13.5" (343 mm)
	Penetration, max.
	14.3" (363 mm)
	Ground clearance, max. raised
	14.2" (361 mm)
	Shank positions (vertical)
	2

HYDRAULIC CONTROL SYSTEM

Pump, tandem gear.	Cylinders, bore and stroke
Output @ 500 psi (3.45 MPa)	Lift (2)
& rated engine rpm	Angle (2)
18.4 gpm (69.6 l/min)	Tilt (1)
Relief valve setting	Reservoir with sight gauge, system capacity, right fender mounted,
Blade lift & ripper	includes cylinders & lines
Tilt	13.5 gal (51 l)

TD-8R

CRAWLER DOZER

STD & LGP



STANDARD EQUIPMENT

- Air cleaner, dry type, with primary and safety elements and service indicator
- Alarm, back-up, 2 level sound
- Alternator, 120 A
- Antifreeze, -34°F (-37°C)
- Battery, (1) 12 V, 815 CCA, maintenance free
- Canopy ROPS/FOPS (SAE J1040, J231) with roof extension, roof headliner, mirror
- Cooling module; includes radiator, transmission oil cooler and charge air cooler; isolation mounted
- Counterweights, front idler
- Cup holder
- Decelerator/brake – right pedal and brake – left pedal, brake pedal lock button, foot operated
- Engine hood, solid
- Engine side doors, perforated
- Engine speed control knob, L.H. location
- Fan, blower
- Filters, with “spin-on” elements: engine oil, fuel, power train, equip. hyd.
- Guards: crankcase with pull hook, lights, radiator, transmission, rock deflector, fan, fuel tank bottom and back-up alarm
- Hitch, retrieval
- Horn
- Hydraulics, 3-spool valve, “T” control
- Instruments:
 - Gauges: fuel level, coolant temperature, engine oil pressure, power train oil temperature, voltmeter, hourmeter
 - Warning lights: transmission filter service indicator, air filter and hydraulic filter service indicator
- Lights, 2 front, 1 rear, halogen type
- Muffler, underhood with exhaust pipe and elbow
- Power train diagnostic check panel w/brake release port
- Protection guard for fuel tank and filler
- Radiator guard door, louvered
- Seat belt (SAE J386) – 3” wide, retractable
- Seat, suspension type with adjustable arm rests
- Starting aid – air grid heater
- Starting, 12 V
- Steering & transmission, left hand single lever control, joystick w/safety lever
- Strainer, fuel
- Tools compartment
- Torque converter, single stage
- Track adjusters, hydraulic
- Track chains, sealed & lubricated (LTS) with split master links, 37 links
- Track frame, 6 rollers, 54” (1.37 m) gauge, rigid type, lifespan lubricated rollers and idlers, front and rear chain guides
- Track frame covers
- Track shoes, 15” (381 mm), set of 74
- Transmission, full power shift, 3 speeds forward, 3 reverse
- Water separator, fuel system

OPTIONAL ATTACHMENTS

- Air conditioner/heater/pressurizer/defroster
- Angle dozer 2.20 cu.yd (1.68 cu.m), standard width, inside arm w/hyd. tilt & angle, for STD
- Angle dozer, 1.90 cu.yd (1.45 cu.m), wide, inside arm w/hyd. tilt & angle, for LGP
- Battery, cold start, 12 V, 960 CCA
- Cab, ROPS/FOPS with sound suppression, wipers (4) and washers, mirror, dome light & tinted safety glass
- Defroster fan (for use w/cab)
- Forestry front sweeps w/exhaust pipe (for use w/cab or canopy ROPS/FOPS)
- Guards:
 - track roller, std. strength
 - track roller, full length, heavy duty type
- Heater/pressurizer/defroster
- Hood, perforated (blower fan recommended)
- Hydraulics, 4-spool valve, 2 levers (“T”+ single), for use w/ripper or auxiliary attachments
- Mirrors, 2 pcs (for use w/cab)
- Resonator, exhaust
- Ripper, multi-shank w/3 teeth (provision for 5 teeth)
- Screening package, black painted (Canopy ROPS for screens installation must be ordered)
 - screens, front
 - screen, rear
 - doors and side screens w/third post
 - screen, overhead, for upper front lights protection (for use w/sweeps)
- Seat, suspension type with adjustable arm rests (for use with cab)
- Track frame for LGP applications, 6 rollers, 61” (1.55 m) gauge, rigid type
- Track shoes:
 - 15” (381 mm) w/mud relief, 17” (432 mm) set of 74, for STD
 - 24” (610 mm), set of 74, for LGP
- Vandalism protection

Specifications subject to change without notice. Illustrations may include optional attachments and accessories and may not include all standard equipment.

NOTE: Low Ground Pressure (LGP) tractors are designed for use in mud, snow and other soft ground applications.

Use in hard or rocky conditions will reduce undercarriage life and can cause damage to components.

DRESSTA NORTH AMERICA, LTD.

3 TIMBER COURT
 BOLINGBROOK, IL 60440
 phone (630) 759 9530 fax (630) 759 9534
 Toll free (877) DNA 2001
www.dresstanorthamerica.com