



DRESSTA TD-25M LA

LANDFILL CRAWLER DOZER

EXTRA



■ **Net Horsepower**
330 hp (246 kW)

■ **Blade Capacity**
26.9 yd³ (20.6 m³)
33.4 yd³ (25.5 m³)

■ **Operating Weight**
92,615 lb (42 010 kg)
94,070 lb (42 670 kg)

TD-25M LA

LANDFILL CRAWLER DOZER

- Comfortable, sound suppressed cab
- Large capacity blades
- Two-speed geared steering
- Joystick for transmission and steering module control



ENGINE

* Make and Model	CUMMINS QSX15
Type	In-line, 6-cylinder
Aspiration	Turbocharged and CAC
Fuel system	HPI Electronic
Gross Horsepower SAE J1995	375 hp (280 kW)
** Net Horsepower SAE J1349/ISO 9249	330 hp (246 kW)
Rated rpm	1800 rpm
Max. torque @1400 rpm	1,346 lb-ft (1825 Nm)
Displacement	912 in ³ (15 l)
Bore and Stroke	5.39" x 6.65" (137 x 169 mm)
Air cleaner	dry type with exhaust aspirated primary, safety elements and service indicator

* Meets EPA Tier 3 emission regulations

**Net Horsepower at the minimum speed of hydraulic fan 370 hp (277 kW)

TRANSMISSION & TORQUE CONVERTER

Modular, countershaft type power shift, electro-hydraulic control. Preset travel speed selection and auto-downshift. Single stage 16" (415 mm) torque converter with a 2.45:1 stall ratio drives to transmission through a double universal joint.

TRAVEL SPEEDS

Gear	Range	Forward		Reverse	
		mph	(km/h)	mph	(km/h)
1 st	Low	1.9	(3.0)	2.3	(3.7)
	High	2.4	(3.9)	2.9	(4.7)
2 nd	Low	3.2	(5.1)	3.8	(6.1)
	High	4.1	(6.6)	4.9	(7.9)
3 rd	Low	5.0	(8.0)	6.0	(9.6)
	High	6.4	(10.3)	7.6	(12.3)

STEERING & BRAKING

Two-speed geared steering module provides gradual turns while maintaining full power to both tracks plus conventional clutch-brake performance for tight or pivot turns. This type of steering system offers superior traction in all types of operations and terrain.

Coupled to 3-speed transmission, the 2-speed steering provides 6 speeds forward and 6 reverse. The left hand joystick controls transmission and steering drive for up and down shifting, steering, Hi/Lo selection and LH/RH gradual geared turn.

Foot pedal applies both brakes for parking and downhill control. Brakes are spring applied and hydraulically released.

FINAL DRIVES

Double-reduction with planetary final drive stage provides desired gear reduction at the sprocket. Eight-piece bolt-on sprocket distributes wear evenly over track bushings letting every tooth ride free one-half of the time to reduce wear. Sprocket segments are replaceable without removing track frames.

TRACK FRAME

All-welded heavy box section track frame is kept in alignment with track frame guides providing true vertical oscillation.

Track rollers, each side	7
Top idlers, each side	2
Front idlers (drum type)	1
All rollers and idlers	lifespan lubricated
Oscillation at center of front idler	16" (406 mm)

TRACKS

Lubricated Track System (LTS) virtually eliminates internal pin and bushing wear through use of a patented seal assembly.

The split master link reduces chain removal and installation time.

Track shoe width, standard	22" (560 mm)
Strutted track link pitch	9.86" (250 mm)
Track shoes, each side	38
Ground contact area	5,456 in ² (3.5 m ²)
Ground pressure (w/std. equipment)	17 psi (117 kPa)
Height of grouser	3" (76 mm)
Track adjustment	full hydraulic
Ground clearance	22.6" (575 mm)

REFILL CAPACITIES

	US gal	(Liter)
Fuel tank	218	(825)
Cooling system	15	(56)
Crankcase	13	(49)
Transmission system	63	(240)
Final drive, each side	16.9	(64)
Hydraulic reservoir	34	(130)

OPERATING WEIGHT

Includes std. equipment, blade equipment, coolant, lubricants and full fuel tank:

- Semi-U dozer	92,615 lb (42 010 kg)
- Full-U dozer	94,070 lb (42 670 kg)

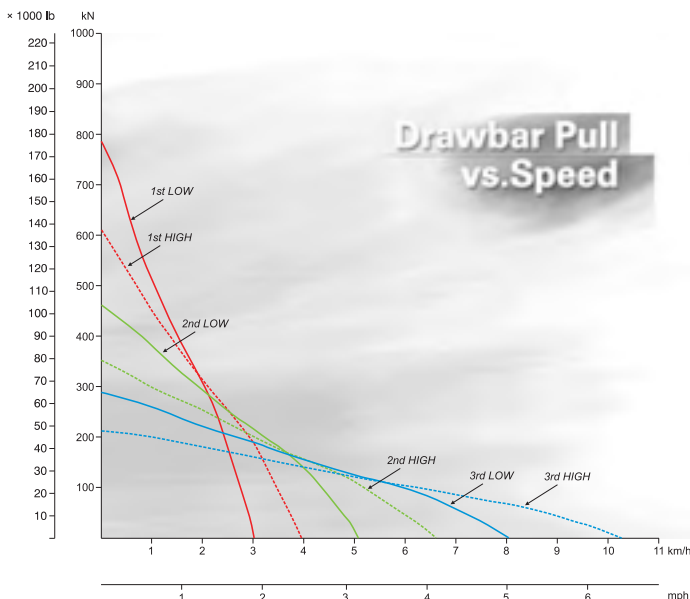

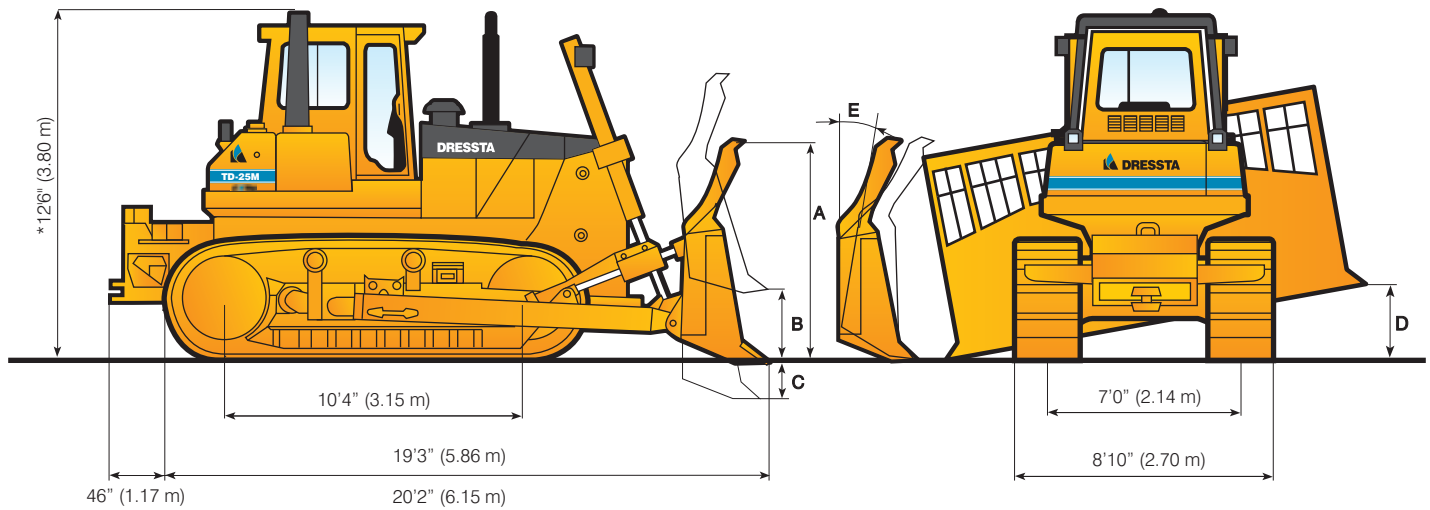

* DIMENSION INCLUDES 3" (76 mm) GROUSER HEIGHT

OVERALL DIMENSIONS WITH EQUIPMENT

BLADE SELECTION	SEMI-U	FULL-U
Length with blade and rear striker bars	23'1" (7.03 m)	24' (7.32 m)
Length with blade and multi-shank ripper	27'6" (8.38 m)	28'5" (8.65 m)
Length with blade and single shank ripper	29'4" (8.94 m)	30'3" (9.21 m)
Width over trunnions	10'6" (3.21 m)	10'6" (3.21 m)

BLADE SPECIFICATIONS

BLADE SELECTION		SEMI-U	FULL-U
Blade Capacity, SAE J1265		26.9 yd ³ (20.6 m ³)	33.4 yd ³ (25.5 m ³)
Blade Dimensions:	- width over end bits	159.4" (4.05 m)	171.3" (4.36 m)
	- height, struts centered A	98.2" (2.50 m)	100.9" (2.56 m)
Max. lift, straight	B	50" (1.27 m)	50" (1.27 m)
Max. drop below ground level	C	23.6" (600 mm)	23.6" (600 mm)
Max. tilt adjustment	D	34.6" (880 mm)	37.2" (945 mm)
Max. pitch adjustment	E	10°	10°
Weight of blade equipment		16,116 lb (7310 kg)	17,570 lb (7970 kg)

RIPPER SPECIFICATIONS

RIPPER SELECTION	MULTI-SHANK	SINGLE-SHANK	
		Standard	Deep
Tool Beam			
Overall width	98" (2 485 mm)	57" (1 450 mm)	57" (1 450 mm)
Cross section (height x width)	15" x 18.8" (380 x 478 mm)	15.7" x 21.7" (400 x 550 mm)	15.7" x 21.7" (400 x 550 mm)
Ground clearance under tool beam:	- ripper raised	68" (1 544 mm)	62" (1 565 mm)
	- ripper lowered	6.7" (171 mm)	6.1" (154 mm)
Shanks			
Number of shanks per ripper, max.	3	1	1
Spacing center to center	42" (1 067 mm)	-	-
Penetration, max.	29.9" (760 mm)	49.2" (1 250 mm)	66.9" (1 700 mm)
Ground clearance, max. raised	34.2" (868 mm)	30.3" (770 mm)	29.9" (760 mm)
Shank positions (vertical)	2	4	6
Weight			
Complete, including one shank	11,270 lb (5 100 kg)	11,630 lb (5 280 kg)	11,840 lb (5 370 kg)
Each additional shank	700 lb (318 kg)	-	-
Penetration Force	29,494 lb (131.2 kN)	29,786 lb (132.5 kN)	29,786 lb (132.5 kN)
Pryout Force	79,467 lb (353.5 kN)	84,907 lb (377.7 kN)	84,907 lb (377.7 kN)

TD-25M LA

LANDFILL CRAWLER DOZER



HYDRAULIC CONTROL SYSTEM

Multiple vane pumps, driven from torque converter.	Relief valve setting:
Output @ 2146 rpm:	blade lift & ripper 2,500 psi (17.2 MPa)
1 st pump 47 gpm (178 l/min) @ 2,248 psi (15.5 MPa)	tilt 2,670 psi (18.4 MPa)
2 nd pump 27 gpm (102.2 l/min) @ 2,450 psi (16.9 MPa)	Cylinders, bore and stroke:
and pilot pump 8.8 gpm (33.3 l/min) @ 290 psi (2.0 MPa)	blade lift 5.0" x 57.5" (127 x 1460 mm)
	tilt 7.9" x 5.1" (200 x 130 mm)
	tilt/pitch 7.3"/7.9" x 5.1" (185/200 x 130 mm)

STANDARD EQUIPMENT

- Air cleaner, dry type, with exhaust aspirated primary, safety elements and service indicator. Includes turbine type precleaner with debris guard
- Air conditioner/heater/pressurizer/defroster, underseat mounted; A/C condenser, behind roof mounted
- Alarm, back-up
- Alternator, 100A
- Antifreeze, -34°F (-37°C)
- Batteries, (4) 12 V, 1920 CCA, maintenance free, cold start
- Brakes, foot, spring applied, hydraulically released
- Coolant filter conditioner
- Cab with 2 post ROPS, sound suppression, air recirculation system, 2 F & 2 R lights, 4 wipers w/washers, dome light, inside mirror (approved according to ROPS - SAE J1040 and FOPS - SAE J231)
- Cooling module; includes radiator, transmission oil cooler, fuel cooler, hydraulic oil/fan drive oil cooler, charge air cooler; isolation mounted
- Cylinders, lift, with quick drop valve
- Decelerator - right foot pedal and brake - center foot pedal
- Diagnostic centers for power train and equipment hydraulic pressures
- Ecological drains for engine oil, radiator coolant and hydraulic oil
- Engine hood, sloped, perforated type
- Engine side doors, hinged, perforated type
- Exhaust, resonator with elbow
- Fan, hydraulically driven, in-motion variable blade pitch system, airflow reversible
- Filters, engine oil, full flow and by-pass with replaceable "spin-on" elements
- Filters, power train & equipment hydraulics, "spin-on" micro glass type
- Final drive seal guard
- Fuel strainer
- Guards: crankcase, hinged, serve service type with front pull hook, transmission, severe service type, fan, radiator, sprocket rock and dirt deflector
- Horn, electric
- Hydraulic control, 1 valve, 1 lever with pilot operated blade control (lift)
- Instruments:
 - Gauges: fuel level, engine coolant temperature, engine oil pressure, torque converter oil temp., voltmeter, hourmeter, joystick control display
 - Warning lights: air cleaner filter, transmission oil filter, hydraulic oil filter, transmission/clutch oil low pressure, reversed air flow
 - Audible & visual warning system: low engine coolant level, low engine oil pressure, high engine coolant temp., high torque converter oil temp.
- Lights with guards, 2F - lift cylinders mounted, 2R with metal grid covers - fuel tank mounted
- Muffler, under engine hood, insulated
- Portable lamp receptacle
- Radiator guard doors, louvered, two-piece, hinged, quick opening
- Rear access platform
- Receptacle, charging
- Seat belt (SAE J386) - 3" wide, retractable
- Seat, deluxe, air suspension type, fabric cover, adjustable with arm rests, swivel 14° to right
- Special rear, quick opening, perforated type enclosure plates beneath fuel tank
- Starting, 24 V
- Starting aid - air grid heater
- Steel debris deflector bars, below engine side doors
- Steering, planetary type, 2 speed, left hand single lever control (joystick)
- Striker bars, front
- Striker bars, rear. Include rigid drawbar and counterweight (storage space for 6 vertical plates), include 3 plates
- Tools compartment
- Torque converter, single stage
- Track adjusters, hydraulic
- Track chain, sealed and lubricated (LTS) with split master link, 38 links
- Track chain guides, integral
- Track frame, 7 roller, 84" (2140 mm) gauge, oscillating type, lifespan lubricated rollers and idlers
- Track shoes 22" (560 mm), grouser type with clean out holes
- Transmission, power shift, 3 speeds forward, 3 reverse, combined with 2 speed steering provides 6 speeds forward and 6 reverse; preset travel speed selection and auto-downshift
- Vandalism protection for cab & engine enclosures
- Water separator, fuel system
- Winch, electrical, for lowering engine crankcase guard

OPTIONAL ATTACHMENTS

- Air recirculation system with MSHA filters
- AM/FM CD radio
- Blade Equipment:
 - Full-U, with trash rack, 33.4 cu.yd (25.5 cu.m), includes hydraulic tilt (additional counterweight must be ordered)
 - Semi-U, with trash rack, 26.9 cu.yd (20.6 cu.m), includes hydraulic tilt
 - Hydraulic tilt/pitch for Semi-U or Full-U dozer
- Guards:
 - Final drive rock
 - Tank guard, bolted
 - Track roller, full length
 - Additional counterweight, 3 plates (for use with standard rear striker bars)
- Hydraulic controls, 3-spool valve, 2 lever (for use w/ripper)
- Lights, 2F, ROPS mounted
- Mirrors, 2 pcs, exterior
- Ripper, multi-shank w/hydraulic pitch
 - Rear striker bars, ripper frame mtd
 - Ripper shank w/pin, max. 3
- Ripper, single-shank w/hydraulic pitch
 - Rear striker bars, ripper frame mtd
 - Ripper shank, standard dig
 - Ripper shank, deep dig
 - Pin puller, hydraulic
- Screening pkg; cab for screens installation must be ordered:
 - Screens for cab windows (front, rear, side and doors)
 - Screens for cab lights
- Starting/charging receptacle plug assembly with 15 ft cable
- Sun visor in cab
- Tools in metal box
- Track shoes, with clean out holes: 24" (610 mm), 26" (660 mm), 28" (711 mm)

Specifications subject to change without notice. Illustrations and pictures may include optional equipment and may not include all standard equipment.

DRESSTA NORTH AMERICA, LTD.

3 TIMBER COURT
 BOLINGBROOK, IL 60440
 phone (630) 759 9530, fax (630) 759 9534
 Toll Free: (877) DNA - 2001
www.dresstanorthamerica.com