



# DRESSTA TD-20M LA

LANDFILL CRAWLER DOZER  
STD-LT-LGP

## EXTRA

■ **Net Horsepower**  
179 kW (240 hp)

■ **Blade Capacity**  
up to 17.15 m<sup>3</sup>(22.4 yd<sup>3</sup>)

■ **Operating Weight**  
27 210 kg (59,987 lb) STD  
27 770 kg (61,222 lb) LT  
28 240 kg (62,258 lb) LGP



# TD-20M LA

## LANDFILL CRAWLER DOZER

### STD-LT-LGP



- Comfortable, sound suppressed cab
- Large capacity blades
- Two-speed geared steering
- Joystick for transmission and steering module control

#### ENGINE

* Make and Model	CUMMINS QSC8.3
Type	In-line, 6-cylinder
Aspiration	Turbocharged and CAC
Fuel system	HPCR Electronic
Gross Horsepower, SAE J1995	194 kW (260 hp)
** Net Horsepower, SAE J1349/ISO 9249	179 kW (240 hp)
Rated rpm	2200 rpm
Max. torque @1500 rpm	1180 Nm (870 lb-ft)
Displacement	8.3 l (505 in <sup>3</sup> )
Bore and Stroke	114 x 135 mm (4.49" x 5.32")
Air cleaner	dry type with exhaust aspirated primary and safety elements and service indicator

\* Meets EU Stage IIIA and EPA Tier 3 emission regulations

\*\* Net Horsepower at the minimum speed of hydraulic fan 191 kW (256 hp)

#### TRANSMISSION & TORQUE CONVERTER

Modular, countershaft type power shift, electro-hydraulic control.

Preset travel speed selection and auto-downshift.

Single stage 370 mm (14.6") torque converter with a 2.3:1 stall ratio drives to transmission through a double universal joint.

#### TRAVEL SPEEDS

Gear	Range	Forward		Reverse	
		km/h (mph)	km/h (mph)	km/h (mph)	km/h (mph)
1 st	Low	2.9 (1.8)	3.5 (2.2)		
	High	3.8 (2.4)	4.5 (2.8)		
2 nd	Low	5.3 (3.3)	6.2 (3.9)		
	High	6.8 (4.2)	8.0 (5.0)		
3 rd	Low	8.3 (5.2)	9.8 (6.1)		
	High	10.6 (6.6)	12.5 (7.8)		

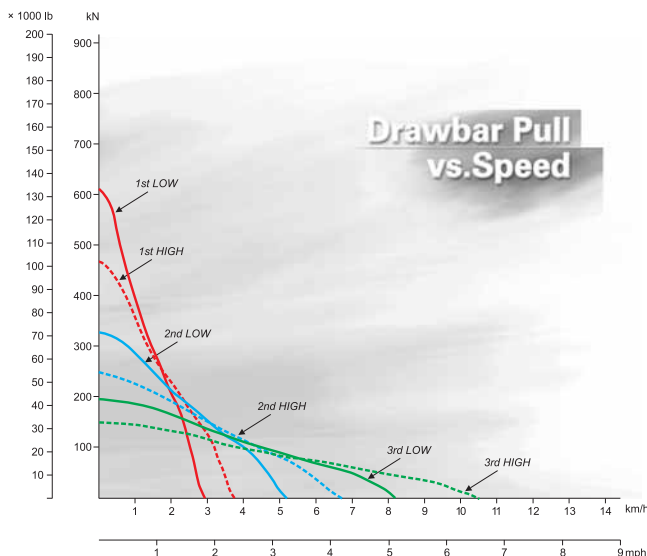

#### STEERING & BRAKING

Two-speed geared steering module provides gradual turns while maintaining full power to both tracks plus conventional clutch-brake performance for tight or pivot turns. This type of steering system offers superior traction in all types of operations and terrain.

Coupled to 3-speed transmission, the 2-speed steering provides 6 speeds forward and 6 reverse. The left hand joystick controls transmission and steering drive for up and down shifting, steering, Hi/Lo selection and LH/RH gradual geared turn.

Foot pedal applies both brakes for parking and downhill control. Brakes are spring applied and hydraulically released.

#### FINAL DRIVES

Double-reduction with outboard planetary final drive stage provides desired gear reduction at the sprocket. Ring-type sprocket distributes wear evenly over track bushings letting every tooth ride free one-half of the time to reduce wear. Final drives or sprockets are replaceable without removing track frames.

#### TRACK FRAME

All-welded heavy box section track frame is kept in alignment with track frame guides providing true vertical oscillation.

Track rollers, each side	6 (7)
Top idlers, each side	2
Front idlers (drum type)	1
All rollers and idlers	lifespan lubricated
Oscillation at center of front idler (STD)	295 mm (11.6")
Oscillation at center of front idler (LT, LGP)	328 mm (12.9")

#### TRACKS

Lubricated Track System (LTS) virtually eliminates internal pin and bushing wear through use of a patented seal assembly. The split master link reduces chain removal and installation time.

	STD	LT	LGP
Track shoe width, std.	560 mm (22")	560 mm (22")	864 mm (34")
Track shoes, each side	40	42	42
Ground contact area	3.2 m <sup>2</sup> (4,972 in <sup>2</sup> )	3.5 m <sup>2</sup> (5,425 in <sup>2</sup> )	5.3 m <sup>2</sup> (8,228 in <sup>2</sup> )
Ground pressure (w/standard equipment)	83.3 kPa (12.1 psi)	78.9 kPa (11.3 psi)	52.0 kPa (7.6 psi)

Height of grouser	67 mm (2.63")
Ground clearance	460 mm (18.1")

#### REFILL CAPACITIES

	Liter	(US gal)
Fuel tank	490	(130)
Cooling system	50	(13.2)
Crankcase	23	(6.1)
Transmission system	173	(45.8)
Final drive, each side	38	(10)
Hydraulic reservoir	115	(30.4)

#### OPERATING WEIGHT

Includes standard equipment and full fuel.

	STD	LT	LGP
Type of blade	Semi-U	Semi-U	Straight
	27210 kg (59,987 lb)	27770 kg (61,222 lb)	28240 kg (62,258 lb)

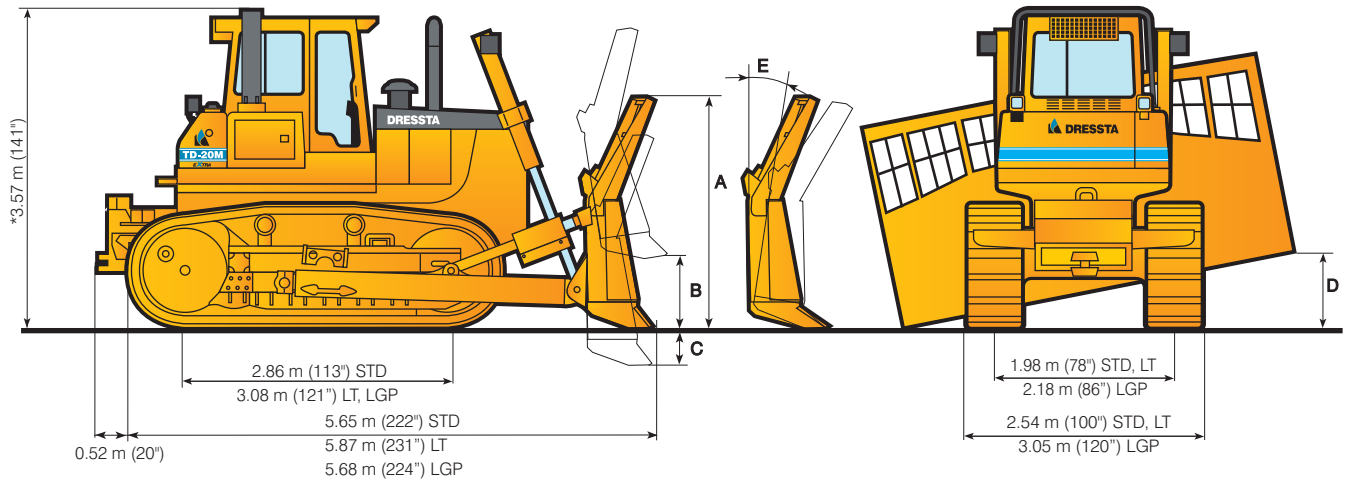

\*INCLUDES 67 mm (2.63") GROUSER HEIGHT

## OVERALL DIMENSIONS WITH EQUIPMENT

BLADE SELECTION		SEMI-U	FULL-U	STRAIGHT
Length with blade and rear striker bars	STD	5.98 m (19'7")	6.22 m (20'5")	-
	LT	6.20 m (20'4")	6.44 m (21'2")	-
	LGP	-	-	6.02 m (19'9")
Length with blade and multi-shank ripper	STD	6.89 m (22'7")	7.13 m (23'5")	-
	LT	7.11 m (23'4")	7.35 m (24'1")	-
Width over trunnions		2.89 m (9'6")	2.89 m (9'6")	3.32 m (10'11")

## BLADE SPECIFICATIONS

BLADE SELECTION		SEMI-U	FULL-U	STRAIGHT
UNDERCARRIAGE		STD & LT	STD & LT	LGP
Blade Capacity, SAE J1265		14.10 m³ (18.4 yd³)	17.15 m³ (22.4 yd³)	13.0 m³ (17.0 yd³)
Blade Dimensions: – width over end bits		3.5 m (138")	3.86 m (152")	4.37 m (172")
– height, struts centered A		2.21 m (87")	2.23 m (88")	2.02 m (80")
Max. lift, straight B	STD	1150 mm (45")	STD 1150 mm (45")	1210 mm (47.6")
	LT	1220 mm (48")	LT 1220 mm (48")	
Max. drop below ground level C	STD	505 mm (19.9")	STD 505 mm (19.9")	522 mm (20.6")
	LT	532 mm (20.9")	LT 532 mm (20.9")	
Max. tilt adjustment D		670 mm (26.3")	720 mm (28.3")	660 mm (26")
Max. pitch adjustment E		10°	10°	-
Weight of blade equipment		3750 kg (8,267 lb)	4200 kg (9,259 lb)	3050 kg (6,724 lb)

## RIPPER SPECIFICATION

<b>TOOL BEAM</b>		<b>SHANKS</b>	
Overall width .....	2.13 m (84")	Number of shanks, max.....	3
Cross section, height x width.....	305 x 381 mm (12" x 15")	Spacing center to center .....	991 mm (39")
Ground clearance under tool beam:		Penetration, max.....	700 mm (27.6")
- ripper raised.....	1295 mm (51")	Ground clearance, max. raised.....	596 mm (23.5")
- ripper lowered.....	178 mm (7")	Shank positions (vertical).....	2
<b>WEIGHT</b>		Penetration force .....	91.1 kN (20,479 lb)
Complete, including one shank .....	2900 kg (6,400 lb)	Pryout force .....	282.2 kN (63,439 lb)
Each additional shank.....	196 kg (432 lb)		



# TD-20M LA

## LANDFILL CRAWLER DOZER

### STD-LT-LGP



## HYDRAULIC CONTROL SYSTEM

Multiple gear pumps, driven from torque converter.

Output @ 6.89 MPa (1,000 psi) and 2330 rpm :

1 st pump .....142 l/min (37.5 gpm)

2 nd pump .....62.5 l/min (16.5 gpm)

and pilot pump output @ 2.07 MPa (300psi) .....35.2 l/min (9.3 gpm)

Relief valve setting:

blade lift & ripper .....16.9 MPa (2,450 psi)

tilt .....17.9 MPa (2,600 psi)

Cylinders, bore and stroke:

lift ..... 110 x 1300 mm (4.33" x 51.18")

tilt ..... 180 x 146.5 mm (7.09" x 5.73")

tilt/pitch ..... 180/165.1 x 146.5 mm (7.09"/6.5" x 5.73")

## STANDARD EQUIPMENT

- Air cleaner, dry type, with exhaust aspirated primary, safety elements and service indicator. Includes turbine type precleaner with debris guard
- Air conditioner/heater/pressurizer/defroster, underseat mounted; A/C condenser, behind roof mounted
- Alarm, back-up
- Alternator, 80 A
- Antifreeze, -37°C (-34°F)
- Batteries, (2)12 V, 815 CCA, maintenance free
- Brakes, foot, spring applied, hydraulically released
- Cab with 2 post ROPS, sound suppression, air recirculation system, 2 F and 2 R lights, 4 wipers w/washers, dome light, interior mirror (approved according to ROPS - SAE J1040 and FOPS - SAE J231)
- Coolant filter conditioner
- Cooling module, includes radiator, transmission oil cooler, hydraulic oil/fan drive oil cooler, charge air cooler; isolation mounted
- Decelerator - right foot pedal and brake - center foot pedal
- Diagnostic centers for power train and equipment hydraulic pressures
- Engine hood, sloped, perforated type
- Engine side doors, hinged, perforated type
- Exhaust pipe extension
- Fan, hydraulically driven, airflow reversible
- Filters, engine oil, full flow and by-pass with replaceable "spin-on" elements
- Filters, power train & equipment hydraulics, "spin-on" micro glass type
- Final drive seal guard
- Fuel strainer
- Guards: crankcase, hinged, severe service type with front pull hook, transmission, severe service type, fan, radiator, sprocket rock and dirt deflector
- Horn, electric
- Hydraulic control, 1 valve, 1 lever with pilot operated blade control (lift)
- Instruments:
  - Gauges: fuel level, engine coolant temperature, engine oil pressure, torque converter oil temp., voltmeter, hourmeter, joystick control display
  - Warning lights: air cleaner filter, transmission oil filter, hydraulic oil filter, transmission/clutch oil low pressure
  - Audible & visual warning system: low engine coolant level, low engine oil pressure, high engine coolant temp., high torque converter oil temp.
- Lights with guards, 2 F - lift cylinders mounted, 2 R with metal grid covers - fuel tank mounted
- Muffler, under engine hood, insulated
- Radiator guard doors, louvered, two-piece, hinged, quick opening
- Rear operator platform
- Receptacle, starting/charging
- Seat belt (SAE J386) - 3" wide, retractable
- Seat, deluxe, air suspension type, fabric cover, adjustable with arm rests, swivel 14° to right
- Special rear, quick opening, perforated type enclosure plates beneath fuel tank
- Starting, 24 V
- Starting aid - air grid heater
- Steel debris deflector bars, below engine side doors
- Steering, planetary type, 2-speed, left hand single lever control (joystick)
- Striker bars, front, main frame mounted (STD)
- Striker bars, front, track frame mounted (LT)
- Striker bars, front, track frame mounted (LGP)
- Striker bars, rear. Include rigid drawbar and counterweight (storage space for 5 vertical plates), include 3 plates
- Tools compartment
- Torque converter, single stage
- UNDERCARRIAGE
  - Track frames, oscillating type, lifespan lubricated rollers and idlers. Track adjusters, hydraulic. Track chain end guides, integral.
  - STANDARD (STD)
    - Track chain, sealed and lubricated (LTS) with split master link, 40 links
    - Track frame, 6 roller, 1981 mm (78") gauge
    - Track shoes, 560 mm (22"), grouser type with clean-out holes
  - LONG TRACK (LT)
    - Track chain, sealed and lubricated (LTS) with split master link, 42 links
    - Track chain center guides
    - Track frame, 7 roller, 1981 mm (78") gauge
    - Track shoes, 560 mm (22"), grouser type with clean-out holes
  - LOW GROUND PRESSURE (LGP)
    - Track chain, sealed and lubricated (LTS) with split master link, 42 links
    - Track chain center guides
    - Track frame, 7 roller, 2180 mm (86") gauge
    - Track shoes, 864 mm (34"), extreme clipped corner, grouser type with clean-out holes
- Transmission, power shift, 3 speeds forward, 3 reverse, preset travel speed selection and auto-downshift
- Vandalism protection for cab & engine enclosures
- Water separator fuel system
- Winch electrical, for lowering engine crankcase guard

## OPTIONAL ATTACHMENTS

- Air recirculation system with MSHA filters
- AM/FM CD radio
- Batteries, cold start, 960 CCA
- Blade Equipment, complete:
  - Full-U, with trash rack, 17.15 cu.m (22.4 cu.yd), includes hydraulic tilt (additional counterweight recommended)
  - Semi-U, with trash rack, 14.1 cu.m (18.4 cu.yd), includes hydraulic tilt
  - Hydraulic tilt/pitch for Semi-U or Full-U dozer
  - Straight dozer with trash rack 13.0 cu.m (17 cu. yd), includes hydraulic tilt
- Exhaust extension with guard (for use with forestry sweeps)
- Guards:
  - Additional counterweight, 2 plates (for use with standard rear striker bars)
  - Tank guard, bolted
  - Track roller, full length (STD)
  - Track roller, full length (LT, LGP)
- Hydraulic controls, 3-spool valve, 2 lever (for use w/ripper)
- Inspection lamp 24 V, portable with 6 m (20') cable
- Lights, 2 F, ROPS mounted (not for use with sweeps)
- Lights, 2 F, sweeps mounted (instead of standard 2 F, lift cylinder mounted lights)
- Mirrors, 2 pcs, exterior
- Ripper, multi-shank beam w/o hydraulic pitch
  - Hydraulic pitch for ripper beam
  - Rear striker bars, ripper frame mtd.
  - Ripper shank w/pin, max. 3
- Screen rear (required for winch application), includes deduct for standard operator platform
- Screening package; cab for screens installation must be ordered
  - Screens for cab windows (front, rear, side and doors)
  - Screens for cab lights
- Sun visor in cab
- Striker bars, front, track frame mounted (LT) (for use with 26" track shoes)
- Sweeps forestry, front and rear
- Tools in metal box
- Track shoes, clipped corner with clean out holes (STD&LT): 610 mm (24"), 660 mm (26")

Specifications subject to change without notice. Illustrations and pictures may include optional equipment and may not include all standard equipment.

# DRESSTA Co.Ltd.

Kwiatkowskiego 1, 37-450 Stalowa Wola, POLAND  
 tel. +48 (15) 813 5252, 813 4556 fax: +48 (15) 844 4714  
[www.dressta.com.pl](http://www.dressta.com.pl)