



# TD-14M

CRAWLER DOZER  
STD-LT-LGP



## EXTRA

■ **Net Horsepower**  
120 kW (160 hp)

■ **Blade Capacity**  
up to 4.28 m<sup>3</sup> (5.6 yd<sup>3</sup>)

■ **Operating Weight**  
15550 kg (34,282 lb) STD  
16550 kg (36,486 lb) LT  
17650 kg (38,911 lb) LGP



## Engine

The Cummins QSB6.7 engine meets U.S. EPA Tier 3 and EU Stage IIIA emission standards. This highly successful, common rail engine has charge air cooling and is turbocharged for fuel economy and strong performance. This engine combines the highly efficient electronically controlled fuel injection system with high reliability, durability and long maintenance intervals. The engine is equipped with air grid heater for starting in cold weather.

## Working E

The machine equipped with a blade for construction projects performing sloping road banks, backfi

## Undercarriage arrangements

- Three distinct models of the dozer are available
- Standard (STD)
- Long Track (LT) arrangement which gives t
- Low Ground Pressure (LGP) arrangement s

# TD-14M Extra sets ne

## Equipment

The dozer and a ripper is ideal for all such tasks as clearing and grading, leveling and final grade work.



able for specific job-site applications:

the dozer good balance, makes grading on slopes easy  
specially designed to work in soft and muddy job sites

## Power Train

The modular drive train includes the Cummins engine, single stage torque converter, full power-shift transmission, geared 2-speed steering and the final drives.

Pre-set travel speed selection and automatic downshift system provides the operator with comfortable operation and high productivity without the need for manual downshifting in many operations.

The high capacity brakes are operated by a centrally located foot pedal.

# new performance standards



The modern and comfortable six sided cab provides the operator superior all-around visibility and excellent view of both the blade and the ripper equipment.

The sound suppressed cab with:

- air recirculation system
- pressurized air conditioner/heater
- adjustable air suspension seat with arm rests
- AM/FM radio, CD with MP3/USB compatibility
- in-cab and outside mounted mirrors
- interior light and retractable sun visor is protected by ROPS/FOPS to meet SAE J1040, J231 standards.

# Durable construction

Semi-U blade of 4.28 m<sup>3</sup> (5.6 yd<sup>3</sup>) (STD)



6-way hydraulic angle blade of 3.2 m<sup>3</sup> (4.2 yd<sup>3</sup>) (STD & LT) and 3.8 m<sup>3</sup> (5.0 yd<sup>3</sup>) (LGP)



Straight blade of 3.05 m<sup>3</sup> (4.0 yd<sup>3</sup>) (LGP)



A variety of blades suitable for various operating conditions and job requirements are available. STD and LT versions can be equipped with Semi-U or 6-Way blades and the LGP version mounts either a Straight or 6-Way blade with the full width 915 mm (36") track shoe.





The instrument panel provides the operator with the information about the condition of the machine during operation.

The left hand joystick controls transmission and steering drive for up and down shifting, steering Hi/Lo selection and LH/RH gradual turns.

The right hand ergonomical levers control blade and ripper movements. Pilot operated hydraulic controls are offered as an option.

yd<sup>3</sup>)



ped  
hoes.

The optional three-shank, parallelogram type ripper is ideal for ripping in tough material.



# Specification

## ENGINE

|                                    |   |
|------------------------------------|---|
| * Make and Model                   | Cummins QSB6.7                                    |
| Type                               | In-line, 6-cylinder                               |
| Aspiration                         | Turbocharged and CAC                              |
| Fuel system                        | HPCR Electronic                                   |
| Gross Horsepower, SAE J1995        | 129 kW (173 hp)                                   |
| Net Horsepower, SAE J1349/ISO 9249 | 120 kW (160 hp)                                   |
| Rated rpm                          | 1800 rpm  |
| Max. torque @ 1350 rpm             | 893 Nm (659 ft-lb)                                |
| Displacement                       | 6.7 l (408 in <sup>3</sup> )                      |
| Bore and stroke                    | 107 x 124 mm (4.21" x 4.88")                      |
| Air cleaner                        | dry type, dual stage<br>with dust discharge valve |

\*Meets EU Stage IIIA and EPA Tier 3 emission regulations

## TRANSMISSION & TORQUE CONVERTER

Modular, countershaft type power shift, electro-hydraulic control. Preset travel speed selection and auto-downshift. Single stage 370 mm (14.6") torque converter with a 2.1:1 stall ratio drives to transmission through a double universal joint.

## TRAVEL SPEEDS

| Gear | Range | Forward |       | Reverse |       |
|------|-------|---------|-------|---------|-------|
|      |       | km/h    | (mph) | km/h    | (mph) |
| 1 st | Low   | 2.9     | (1.8) | 3.6     | (2.2) |
|      | High  | 4.0     | (2.5) | 4.8     | (3.0) |
| 2 nd | Low   | 5.0     | (3.1) | 6.0     | (3.7) |
|      | High  | 6.6     | (4.1) | 8.0     | (5.0) |
| 3 rd | Low   | 8.2     | (5.1) | 9.8     | (6.1) |
|      | High  | 10.8    | (6.7) | 12.9    | (8.0) |

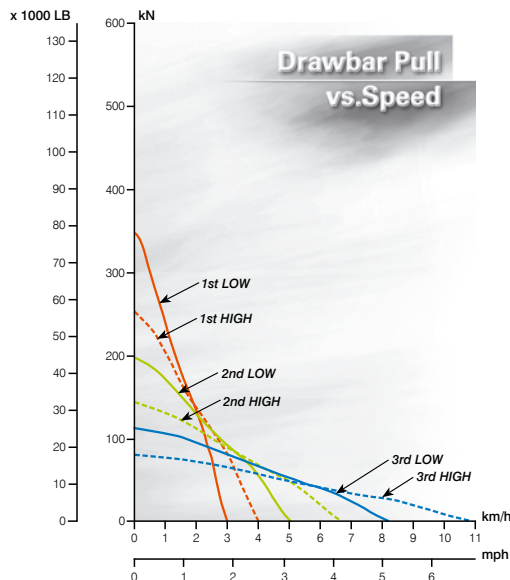

## STEERING & BRAKING

Two speed geared steering module provides gradual turns while maintaining full power to both tracks plus conventional clutch-brake performance for tight or pivot turns. This type of steering system offers superior traction in all types of operations and terrain.

Coupled to 3-speed transmission, the 2-speed steering provides 6 speeds forward and 6 reverse. The left hand joystick controls transmission and steering drive for up and down shifting, steering, Hi/Lo selection and LH/RH gradual geared turn.

Foot pedal applies both brakes for parking and downhill control. Brakes are spring applied and hydraulically released.

## FINAL DRIVES

Double-reduction module provides desired gear reduction at the sprocket. Ring-type sprocket distributes wear evenly over track bushings, letting every tooth ride free one-half of the time to reduce wear. Final drives or sprockets are replaceable without removing track frames.

## TRACK FRAME

All-welded heavy box section track frame is kept in alignment with track frame guides providing true vertical oscillation.

|  |                     |
|--|---------------------|
| Track rollers, each side STD (LT, LGP) | 7(8)                |
| Top idlers, each side                  | 2                   |
| Front idlers (drum type)               | 1                   |
| All rollers and idlers                 | lifespan lubricated |

## TRACKS

Lubricated Track System (LTS) virtually eliminates internal pin and bushing wear through use of a patented seal assembly. The split master link reduces chain removal and installation time.

|                                    | STD   | LT  | LGP   |
|------------------------------------|---|---|---|
| Track shoe width, standard         | 560 mm (22")                                | 560 mm (22")                                | 915 mm (36")                                |
| Track shoes, each side             | 40  | 46  | 46  |
| Ground contact area                | 2.9 m <sup>2</sup> (4,495 in <sup>2</sup> ) | 3.6 m <sup>2</sup> (5,580 in <sup>2</sup> ) | 5.8 m <sup>2</sup> (8,990 in <sup>2</sup> ) |
| Ground pressure (w/std. equipment) | 55.5 kPa (8.0 psi)                          | 47.5 kPa (6.9 psi)                          | 31.4 kPa (4.6 psi)                          |
| Height of grouser                  | 65 mm (2.56")                               |   |   |
| Ground clearance                   | 430 mm (16.9")                              |   |   |

## REFILL CAPACITIES

|                             | Liter | (US gal) |
|-----------------------------|-------|----------|
| Fuel tank                   | 380   | (100)    |
| Cooling system              | 34    | (9)      |
| Crankcase w/filter          | 18.5  | (4.9)    |
| Transmission system         | 125   | (33)     |
| Final drive, each (STD, LT) | 28    | (7.4)    |
| Final drive, each (LGP)     | 46    | (12)     |
| Hydraulic reservoir         | 59    | (15.6)   |

## OPERATING WEIGHT

Includes standard equipment, 6-way blade and full fuel tank:

|                  | STD                   | LT                    | LGP                   |
|------------------|-----------------------|-----------------------|-----------------------|
| Canopy ROPS/FOPS | 15 550 kg (34,282 lb) | 16 550 kg (36,486 lb) | 17 650 kg (38,911 lb) |
| Cab ROPS         | 16 100 kg (35,494 lb) | 17 100 kg (37,699 lb) | 18 200 kg (40,124 lb) |

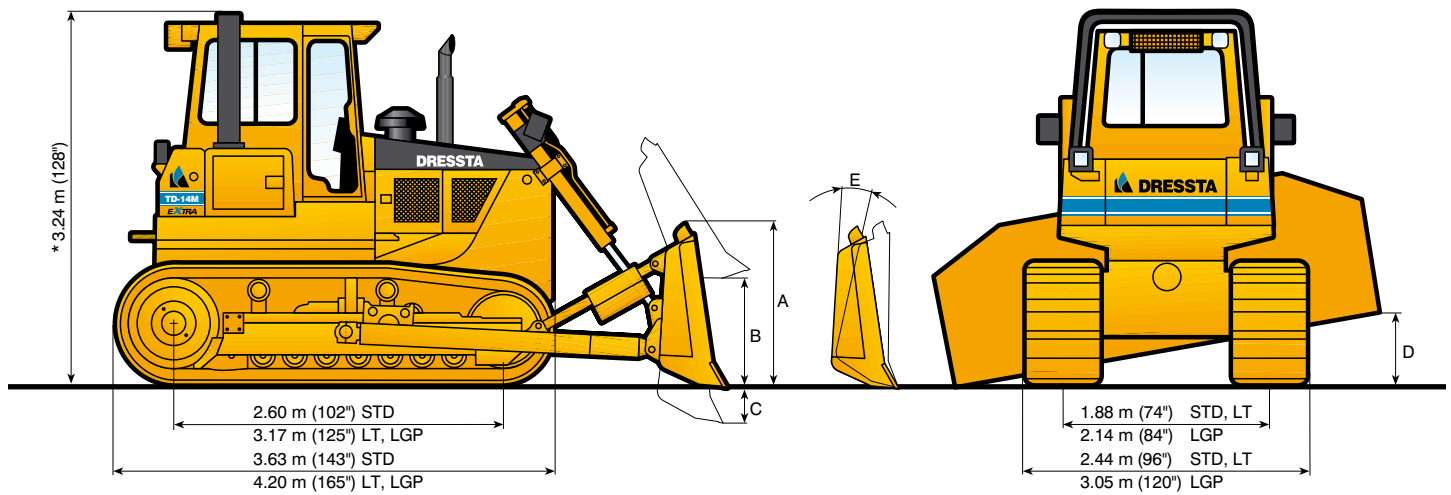

\* DIMENSION INCLUDES 65 mm (2.56") GROUSER HEIGHT

## OVERALL DIMENSIONS WITH EQUIPMENT

|                               | UNDERCARRIAGE | BLADE SELECTION |                |                 |                |
|-------------------------------|---------------|-----------------|----------------|-----------------|----------------|
|                               |               | SEMI-U          | 6-WAY          | STRAIGHT        | 6-WAY          |
| Length with blade and drawbar | STD           | 5.13 m (16'10") | 5.32 m (17'5") |                 |                |
|                               | LT            | 5.69 m (18'8")  | 5.54 m (18'2") |                 |                |
|                               | LGP           | —               | —              | 5.50 m (18')    | 5.54 m (18'2") |
| Length with blade and ripper  | STD           | 6.30 m (20'8")  | 6.49 m (21'4") | —               | —              |
|                               | LT            | 6.87 m (22'16") | 6.72 m (22'1") | —               | —              |
| Width, blade angled           | STD & LT      | —               | 2.92 m (9'7")  | —               | —              |
|                               | LGP           | —               | —              | —               | 3.48 m (11'5") |
| Width over trunnions          | STD & LT      | 2.71 m (8'11")  | —              | —               | —              |
|                               | LGP           | —               | —              | 3.30 m (10'10") | —              |

## BLADE SPECIFICATIONS

| UNDERCARRIAGE                                       | BLADE SELECTION | STD&LT                                     |  | LGP  |  |
|---|-----------------|--|--|--|--|
|   |                 | SEMI-U                                     | 6-WAY                                      | STRAIGHT                                   | 6-WAY                                      |
| Track shoes   |                 | 22"/24"                                    | 22"/24"                                    | 36"  | 36"  |
| Blade capacity, SAE J1265                           |                 | 4.28 m <sup>3</sup> (5.6 yd <sup>3</sup> ) | 3.20 m <sup>3</sup> (4.2 yd <sup>3</sup> ) | 3.05 m <sup>3</sup> (4.0 yd <sup>3</sup> ) | 3.80 m <sup>3</sup> (5.0 yd <sup>3</sup> ) |
| Blade dimensions: – width over end bits<br>– height |                 | 3.37 m (133")                              | 3.22 m (127")                              | 3.70 m (146")                              | 3.83 m (151")                              |
|   | A               | 1.23 m (48")                               | 1.20 m (47")                               | 1.02 m (40")                               | 1.17 m (46")                               |
| Max. lift, straight                                 | B               | STD 990 mm (39")<br>LT 1060 mm (42")       | STD 1090 mm (42.9")<br>LT 1086 mm (42.7")  | 1056 mm (41.6")                            | 1085 mm (42.7")                            |
|   | C               | STD 515 mm (20.3")<br>LT 500 mm (19.7")    | STD 580 mm (22.8")<br>LT 536 mm (21.1")    | 500 mm (19.7")                             | 536 mm (21.1")                             |
| Max. tilt adjustment                                | D               | STD 545 mm (21")<br>LT 510 mm (20")        | 510 mm (20")                               | 595 mm (23")                               | 595 mm (23")                               |
|   |                 | —  | 25°  | —  | 25°  |
| Max. pitch adjustment                               | E               | 9°   | 7°   | 9°   | 8°   |
| Weight of blade equipment                           |                 | 2045 kg (4,508 lb)                         | 2066 kg (4,555 lb)                         | 1955 kg (4,310 lb)                         | 2202 kg (4,855 lb)                         |

## RIPPER SPECIFICATION

| TYPE  | MULTI-SHANK             |
|---|-------------------------|
| Tool Beam   |                         |
| Overall width   | 2040 mm (80.3")         |
| Cross section (height x width)  | 229 x 254 mm (9" x 10") |
| Ground clearance under tool beam: – ripper raised<br>– ripper lowered | 1160 mm (46")           |
|   | 60 mm (2.4")            |
| Shanks  |                         |
| Number of shanks per ripper, max.                                     | 3                       |
| Spacing center to center  | 940 mm (37")            |
| Penetration, max.   | 660 mm (26")            |
| Ground clearance, max. raised   | 568 mm (22")            |
| Shank positions (vertical)  | 2                       |
| Weight  |                         |
| Complete, including one shank   | 1422 kg (3,135 lb)      |
| Each additional shank   | 111 kg (245 lb)         |
| Penetration Force   | 67 kN (15,062 lb)       |
| Pryout Force  | 191 kN (42,937 lb)      |



# TD-14M

## CRAWLER DOZER

### STD-LT-LGP



## HYDRAULIC CONTROL SYSTEM

|  |                      |                             |                              |
|--|----------------------|-----------------------------|------------------------------|
| Pump, tandem gear, driven from torque converter. |                      | Cylinders, bore and stroke: |                              |
| Output @ rated engine rpm .....                  | 114 l/min (30 gpm)   | lift (STD) .....            | 90 x 1100 mm (3.5" x 43.3")  |
| Relief valve setting .....                       | 17.5 MPa (2,540 psi) | lift (LT, LGP) .....        | 90 x 930 mm (3.5" x 36.6")   |
|  |                      | lift (6-way) .....          | 90 x 1000 mm (3.5" x 39.4")  |
|  |                      | tilt .....                  | 140 x 147 mm . (5.5" x 5.8") |

## STANDARD EQUIPMENT

- Air cleaner, dry type, dual stage with dust discharge valve
- Alarm, back-up
- Alternator, 50 A
- Antifreeze, -37°C (-34°F)
- Batteries, (2) 12 V, 815 CCA, maintenance free
- Brakes, foot, spring applied, hydraulically released
- Canopy, 2 post ROPS/FOPS (SAE J1040, J231)
- Cooling module; includes radiator, transmission oil cooler, charge air cooler; isolation mounted
- Decelerator – right foot pedal and brake – center foot pedal
- Diagnostic centers for power train and equipment hydraulic pressures
- Ecological drains for engine oil, radiator coolant and hydraulic oil
- Engine hood, solid, sloped
- Engine side doors, hinged, perforated type
- Exhaust pipe extension with elbow
- Fan, blower
- Filter, engine oil, full flow, "spin-on" type
- Filters, power train, equipment hydraulics, fuel, "spin-on" micro glass type
- Final drive seal guard
- Guards: crankcase, hinged, with front pull hook, transmission, fan, radiator and sprocket rock and dirt deflector
- Hitch, retrieval
- Horn, electric
- Hydraulic control, 2-spool valve, 1 lever (lift/tilt)
- Instruments:
  - Gauges: fuel level, engine coolant temp., engine oil pressure, torque converter oil temp., voltmeter, hourmeter, tachometer, brake lock, joystick control display
  - Warning lights: air cleaner filter, transmission oil filter, hydraulic oil filter, transmission/clutch oil low pressure
  - Audible & visual warning system: low engine coolant level, low engine oil pressure
- Lights with guards, 2F – lift cylinders, 2R – fuel tank mounted
- Muffler, under engine hood, insulated
- Radiator guard door, hinged, louvered
- Rear access steps
- Receptacle, starting/charging
- Seat belt (SAE J386) – 3" wide, retractable
- Seat, deluxe, air suspension type, vinyl cover, adjustable with arm rests, swivel 14° to right
- Starting aid – air grid heater
- Starting, 24 V
- Steering, planetary type, 2 speed, left hand single lever control (joystick)
- Strainers, fuel and hydraulic tanks
- Tools compartment
- Torque converter, single stage
- Transmission power shift, 3 speeds forward, 3 reverse, preset travel speed selection and auto-downshift
- Water separator, fuel system
- UNDERCARRIAGE
  - Track frames, oscillating type, lifespan lubricated rollers and idlers
  - Track adjusters, hydraulic
  - Track chain center guides
  - Track chain end guides, integral
  - STANDARD (STD)
    - Track chain, sealed and lubricated (LTS) with split master link, 40 links
    - Track frame, 7 roller, 1880 mm (74") gauge
    - Track shoes, 560 mm (22") square corner
  - LONG TRACK (LT)
    - Track chain, sealed and lubricated (LTS) with split master link, 46 links
    - Track frame, 8 roller, 1880 mm (74") gauge
    - Track shoes, 560 mm (22") square corner
  - LOW GROUND PRESSURE (LGP)
    - Track chain, sealed and lubricated (LTS) with split master link, 46 links
    - Track frame, 8 roller, 2136 mm (84") gauge
    - Track shoes, 915 mm (36") clipped corner

## OPTIONAL ATTACHMENTS

- AM/FM CD radio
- Batteries, cold start (2) 12 V, 960 CCA
- Blade Equipment (STD & LT):
  - Semi-U Dozer, 4.28 cu. m (5.6 cu. yd); hydraulic tilt
  - Angle Dozer (6-way), 3.20 cu. m (4.2 cu. yd) full hydraulic, inside arm with hydraulic tilt, angle and manual pitch
- Blade Equipment (LGP):
  - Straight Dozer, 3.05 cu. m (4.0 cu. yd); hydraulic tilt
  - Angle Dozer (6-way), 3.8 cu. m (5.0 cu. yd) full hydraulic, inside arm with hydraulic tilt, angle and manual pitch
- Cab and ROPS Equipment:
  - Air conditioner/heater/pressurizer/defroster, underseat mounted; A/C condenser behind roof
  - Air recirculation system with MSHA filters
  - Cab w/sound suppression, 4 wipers w/washers, inside mirror, dome light, tinted safety glass and air recirculation system
  - Heater /pressurizer/ defroster
  - ROPS for cab or forestry attachment
  - Sun visor in cab
  - Sweeps, forestry, front and rear
  - Screen rear (includes deduct for standard rear access steps)
  - Seat, air suspension, fabric cover (for use w/cab)
  - Drawbar, fixed
  - Engine enclosures: perforated hood and perforated side doors
  - Exhaust pipe extension w/guard, for sweeps
  - Guards:
    - Crankcase, severe service w/front pull hook
    - Tank guard, bolted (includes deduct for standard rear access steps)
    - Track roller, full length (STD)
    - Track roller, full length (LT-LGP)
    - Transmission, severe service
  - Hydraulic controls:
    - 2-spool valve, 1 lever (for use with 6-way)
    - 3-spool valve, 2 lever (for use w/ripper and tilt or 6-way)
  - Inspection lamp, 24 V, portable with 6 m (20") cable
  - Instrument panel guard (for use w/Canopy ROPS/FOPS)
  - Lights for Canopy ROPS/FOPS, 2F – 2R
  - Lights for cab, 2F – 2R
  - Lights for cab and sweeps, 2F – 2R
  - Lights, ROPS mounted (not for use with sweeps) for use with cab, 2F
  - Mirrors, 2 pcs. exterior
  - Pilot operated hydraulic controls:
    - 2-spool valve, 1 lever (for use with tilt)
    - 2-spool valve, 1 lever (for use with 6-way)
    - 3-spool valve, 2 lever (for use w/ripper and tilt or 6-way)
  - Ripper, multi-shank, max. 3 shanks
  - Screening package; cab for screens installation must be ordered:
    - Screens for cab windows (front, rear, side and doors)
    - Screens for tractor and cab lights
  - Starting/charging receptacle plug assembly
  - Tools in metal box
  - Track shoes (STD-LT), 610 mm (24") square corner. Access steps on track frame, bolt-on.
  - Vandalism protection

Specifications subject to change without notice. Illustrations and pictures may include optional attachments and accessories and may not include all standard equipment.

# DRESSTA Co.Ltd.

Kwiatkowskiego 1, 37-450 Stalowa Wola, P O L A N D  
 tel. 48 15 813 5252, 813 4556 fax: 48 15 844 4714  
 www.dressta.com.pl